

Safety Couplings

with keyway and two rollers

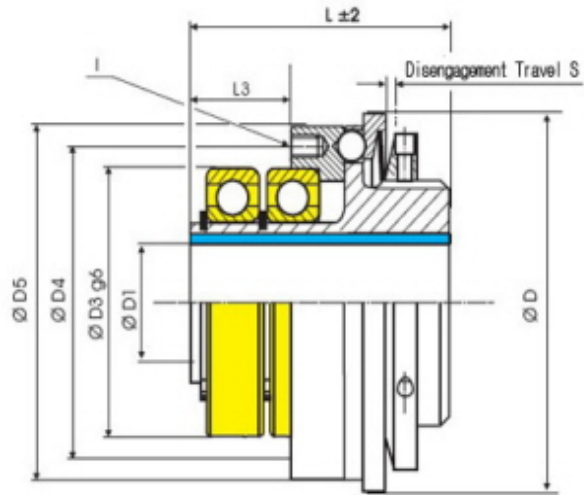
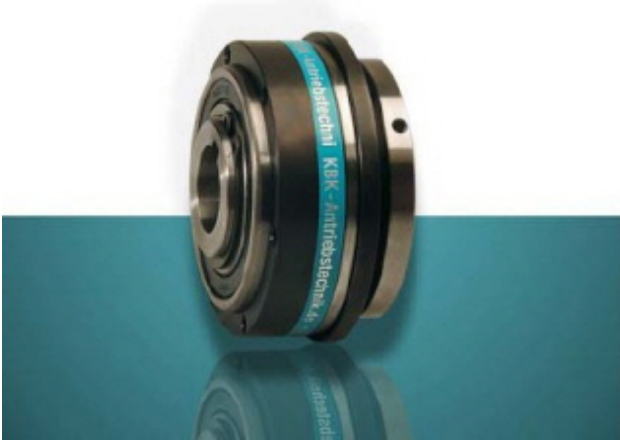

Order Code : **KBK/LL-P-60 - 20H7 - 20Nm - C or D - 2**

Type / Size

Ø D1

Disengagement
Torque

C=Single Position
D=Multi Position

Overload
Torque Range

KBK/LL-P-X	Dimensions (mm)									Technical Ratings				
	Ø D	Ø D1	Ø D3	Ø D4	Ø D5	L	L3	S	I	Overload Torque adjustable		Maximum Speed rpm (1/min)	Mass (kg)	Moment of Inertia J (kg cm ²)
	Outer Ø	Bore Sizes (H7) min~max				Length			6X	1 T _{KN} (Nm)	2 T _{KN} (Nm)			
-10	49	6-12	37	42	47	36	15	0.7	M3	3-7	5-10	12000	0.18	0.4
-30	64	10-16	47	53	60	48.5	20	1.2	M4	5-15	10-30	9400	0.53	2.2
-60	79	15-24	62	69	75	62	26	1.2	M5	13-35	20-60	7800	0.98	6
-80	94	19-29	68	80	90	62	27	2	M6	15-40	30-80	6400	1.7	14
-150	94	19-29	68	80	90	62	27	2	M6	50-130	65-150	5500	1.7	14
-200	109	20-38	80	90	105	71	28	2	M6	30-90	80-200	5500	1.9	23
-300	119	20-42	90	102	115	78	31	2	M8	60-200	150-300	5000	3	44
-500	129	20-50	100	112	125	77	31	2	M8	80-250	200-500	4500	4.5	80
-800	169	30-60	110	125	165	103	38	2	M12	260-600	500-900	3500	13	376
-1400	169	30-60	110	125	165	103	38	2	M12	450-900	800-1400	3500	13	376

* Temperature Range :

-30 °C ~ 120 °C